



Welcome to the new IMS Merchandising Catalogue.

IMS offers a first class service, with many orders despatched within 24 hours of receipt.

The modular product ranges available offer strength, durability and flexibility. These systems are used by the professional shopfitting trade in supermarkets, DIY merchants, fashion stores, cash & carry's and many other environments.

These ranges are sourced from one of Europe's largest producers of commercial shelving (Tegometal), and all products are manufactured to the highest standard.

The costs associated with designing, purchasing and stocking bespoke shelving systems have become uneconomical. Therefore we have selected these products and this partner to ensure that all new products in this manual are fully interchangeable with the systems we currently have, and enable you to effectively merchandise your store in a more affordable manner.

As the majority of items are now standard stocked items they provide the added benefit of being available for a fast turnaround on orders. No more waiting weeks for one or two items!

The range of accessories that complement the new modular systems are also standard stocked items, so again this will reduce lead times on orders and they will also fit with existing systems.

There will now be a mixture of panels rather than just Slat, these will be Perforated and Plain panels along with Slat panels. This will provide greater flexibility in merchandising certain products (eg hand tools) and will allow you greater flexibility on what products you have in what areas of the store.

Product Information

Bay Widths

Bay widths are: 1000mm and 1250mm.

Shelf Depths

Depths: 300mm, 370mm, 470mm

Base Leg

Base leg height: 1400mm and 2200mm
Dimensions are the same as the shelf depths

Base Leg colours are White

Back Panels

There are 3 types of back panel available in 2 main module sizes 1000mm and 1250mm:

Plain: height 200mm and 400mm

Peg: height 400mm only

Slat : height 500mm only



How to order

Simply select what you need from the catalogue and then complete an Order Form. You can either photocopy the Order Form on the rear of this catalogue and fax to IMS, or send an email to: david.imsconcepts@gmail.com

IMS will then supply you with a quotation including delivery charge, noting any items which are not in stock. All delivery charges are calculated by the weight, dimensions and postcode of the purchased goods.

On receipt of your quotation, if you wish to proceed with the order, please raise a Purchase Requisition for your requirements which will be subject to the normal authority release levels and approval from your Regional Director. Please advise IMS of the Purchase Order Number and they will then action your requirements.

Should you have any specific requirements or need any help please contact David Edwards at IMS.

IMS Concepts
18 Bankfield Grange
Off Saddleworth Road
Greetland HX4 8AJ
Tel: 01422 377385
Email: david.imsconcepts@gmail.com

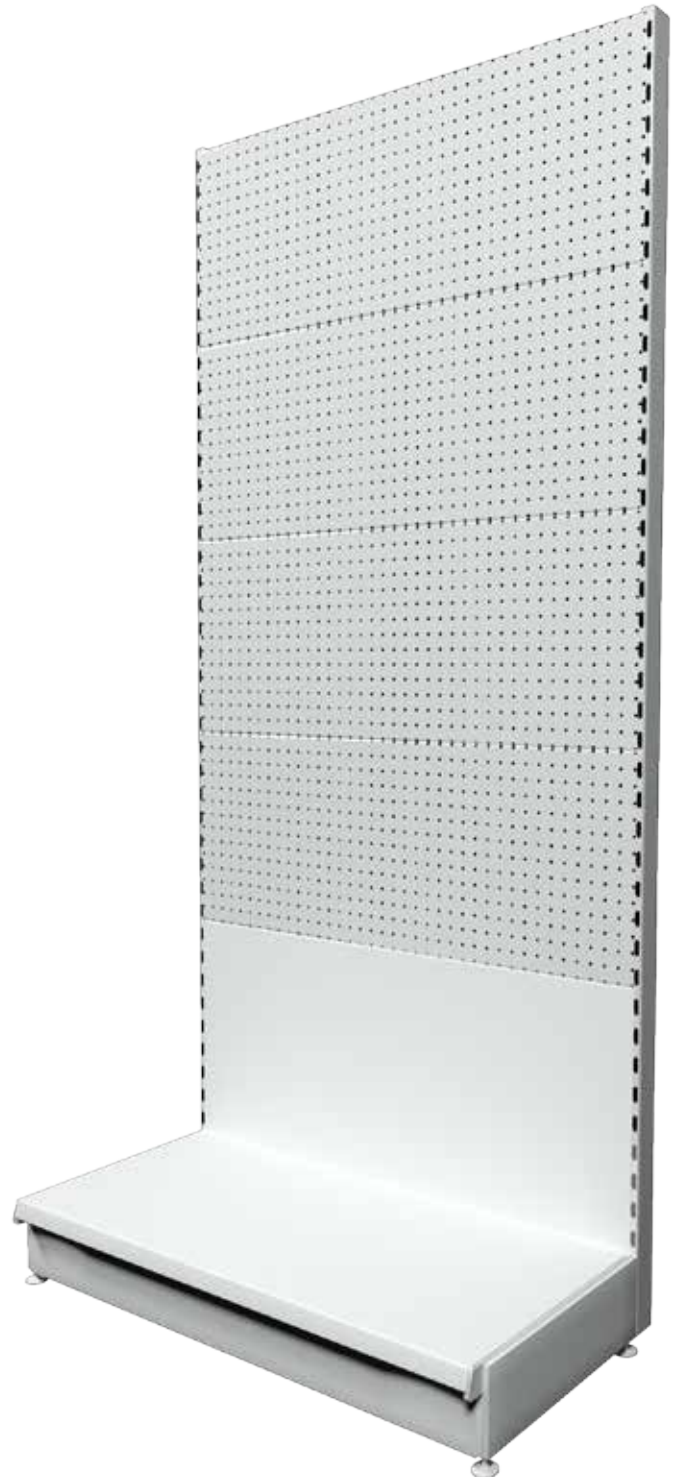

What is merchandising and why should we do it?

What is it? Well it's the silent sales person. Good merchandising improves sales, improves margin, improves customer satisfaction and above all breeds brand customer loyalty.

A few simple rules

The maximum exposure area is in what we call "eye line". If you can see it without moving your head up and down this is eye line. So look for products which are attractive and can be placed into eye line i.e. Clothing, Tools and Power Tools.

Blocking

When we read, we read left to right, but when looking for products we often scan the products but miss the individual item we need. So don't run products across a shelf or a peg metal back panel, run them up and down, in the same way as this page has been set out. This allows the eye and the brain to work together to locate products individually as well as on block.

Traffic flow generators.

Not all of your products are ones that everyone wants to see or buy. So use the ones which will generate foot fall around your centre so that people pass the items they may not need today or did not know

you sold, i.e. Refrigeration close to Tools, Rail Equipment close to Gas Equipment.

Do not forget the three main traffic flow generators - the counter, the toilet and the drinks machine.

It's not difficult to understand, for example, hand tools should flow into power tools, power tools into drill bits, drill bits into grinders, from grinders well I will leave the rest to you.

One big thing which all trade counter operations forget is seasonality. We basically have three seasons in merchandising, winter spring and summer. You should be constantly changing your merchandising mix and product ranges to suit the seasons, i.e. T-shirts and polo shirts for the summer, put the padded coats away until winter arrives.

I hope these few notes have given you some ideas for merchandising your store, but please feel free to ring David on 01422 377385 if you have any specific issues.

Happy merchandising.

David Edwards
IMS Concepts

1 Meter Gondola Bay

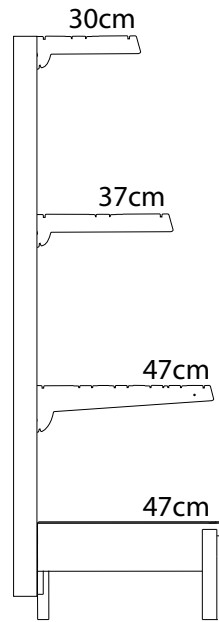

Product Code
GB001
GB002

Product Description
Starter Bay
Continuation Bay
1 x Pegmetal
2 x Plain Back Panels
47 cm
1 x 47 cm
1 x 37cm
1 x 30 cm
140 cm
100 cm

Base Shelf:
Mid Shelf:
Top Shelf:
Height:
Width:

 Jura White

1 Meter Gondola Bay Back to Back

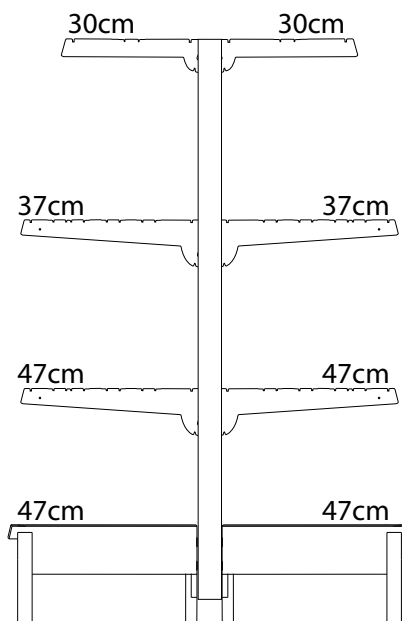

Product Code
GB003
GB004

Product Description
Starter Bay
Continuation Bay
2 x Pegmetal
4 x Plain Back Panels
47 cm
4 x 47 cm
2 x 37 cm
140 cm
100 cm

Base Shelf:
Mid Shelf:
Top Shelf:
Height:
Width:

 Jura White

1 Meter Wall Bay

Product Code
WB001
WB002

Product Description

Starter Bay

Continuation Bay

3 x Pegmetal

2 x Plain Back Panels

47 cm

3 x 47 cm

1 x 37 cm

220 cm

100 cm

Base Shelf:
Mid Shelf:
Top Shelf:
Height:
Width:



Jura White

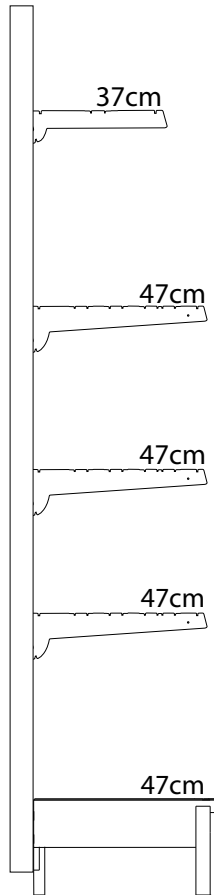

1 Meter Perf Wall Bay

Product Code
WB003
WB004

Product Description

Starter Bay

Continuation Bay

5 x Pegmetal

Base Shelf:

Mid Shelf:

Top Shelf:

Height:

Width:

220 cm

100 cm



Jura White

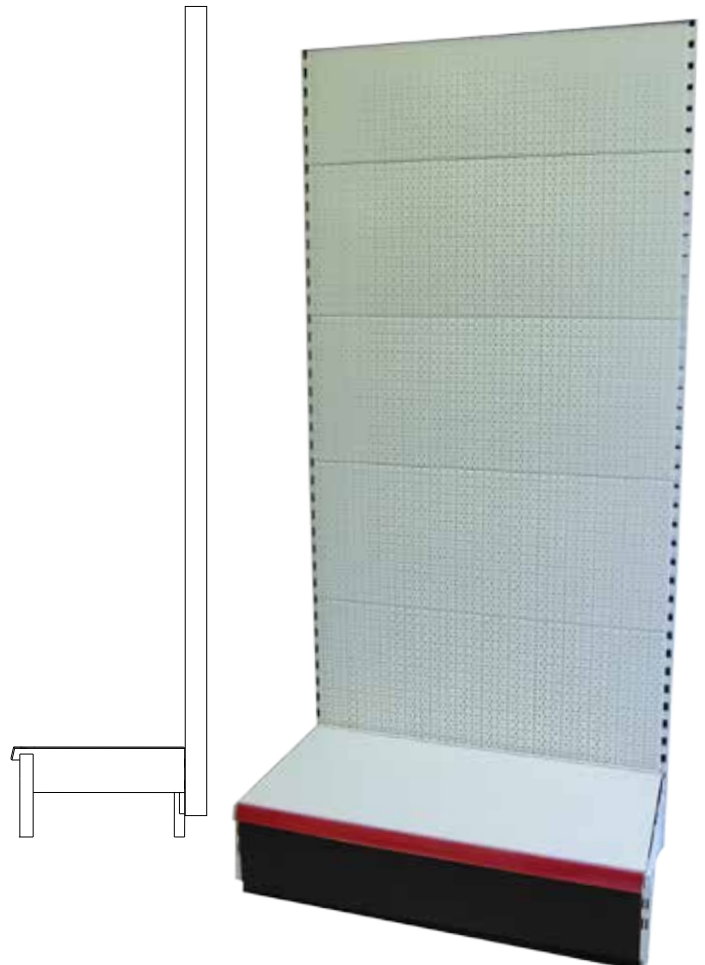

Acrylic Shelf Dividers



Product Code
4-4423-4
4-4424-4

Product Description
Plain Divider 370mm
Plain Divider 470mm

4-4431-44
4-4432-44

Toothed Divider 370mm
Toothed Divider 470mm

4-4415-44
4-4416-44

Front & Rear Riser 1000mm
Front & Rear Riser 1250mm

*Ideal for hose fittings, mig & tig tips and any other small items.

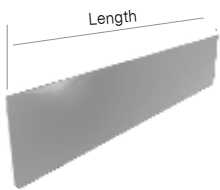

Plain Divider



Toothed Divider

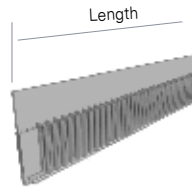

Front & Rear Riser

Wire Shelf Dividers



Product Code
4-4666-88 WDT
4-4667-88 WDT
4-4670-88 WDT
4-4671-88 WDT

Product Description
Wire Divider 80mm x 370mm
Wire Divider 80mm x 470mm
Wire Divider 150mm x 370mm
Wire Divider 150mm x 470mm

4-4661-88WD
4-4201-88 WD
4-4202-88 WD
4-4662-88WD
4-4205-88 WD
4-4206-88 WD

Front Wire Riser 95mm x 665mm
Front Wire Riser 95mm x 1000mm
Front Wire Riser 95mm x 1250mm
Front Wire Riser 170mm x 665mm
Front Wire Riser 170mm x 1000mm
Front Wire Riser 170mm x 1250mm

*Ideal for gloves & bulky items



Plain Divider



Front Riser

Board Holders



Product Code
HB1

Product Description
Board Headers

Kick Plinth - 260mm Base



Product Code
2-0834-68
2-0836-65

Product Description
Kick Plinth 1000mm
Kick Plinth 1250mm

Plinth Drawer To Suit 260mm Base

Product Code
HD2

Product Description
Plinth Drawer for 260mm by 1000mm base

*for storage with the gondola base to suit
470mm base shelf

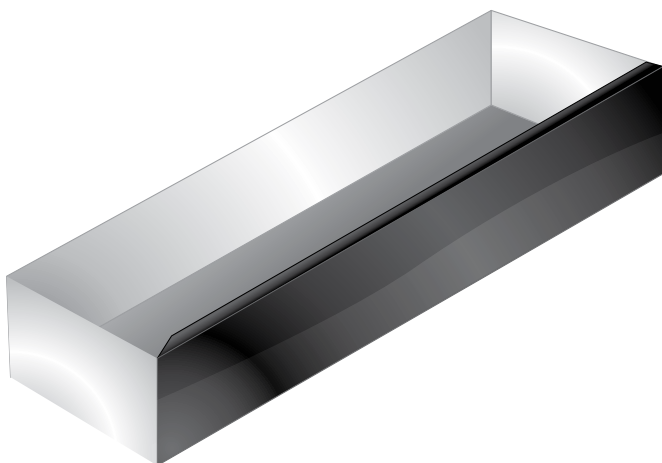

Gondola Cover Strip

Product Code
3-1800-24
3-1128-24

Product Description
Gondola cover strip 1000mm by 60mm, Jura White
Gondola cover strip 1000mm by 60mm, Jura White

*Sheet steel gondola cover strip

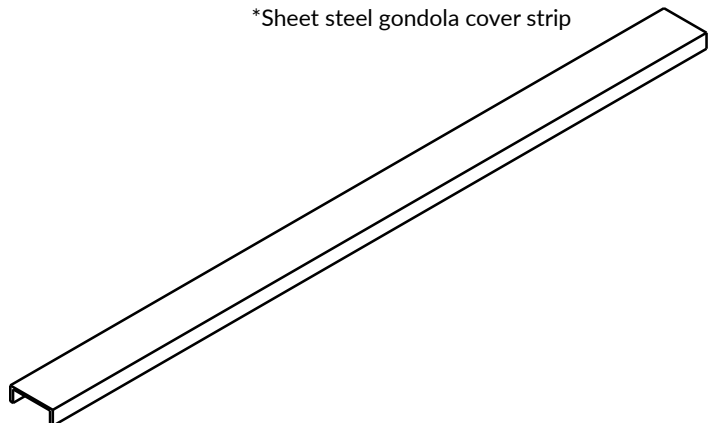

Plain Back Panel

Product Code

3-1193-24
3-1200-24
241-3128
3-1186-24
3-1298-24
241-3164

Product Description

Plain Back Panel 1000mm by 200mm, JuraWhite
Plain Back Panel 1000mm by 400mm, JuraWhite
Plain Back Panel 1000mm by 500mm, JuraWhite
Plain Back Panel 1250mm by 200mm, JuraWhite
Plain Back Panel 1250mm by 400mm, JuraWhite
Plain Back Panel 1250mm by 500mm, JuraWhite

*Sheet steel plain back panels



Jura White

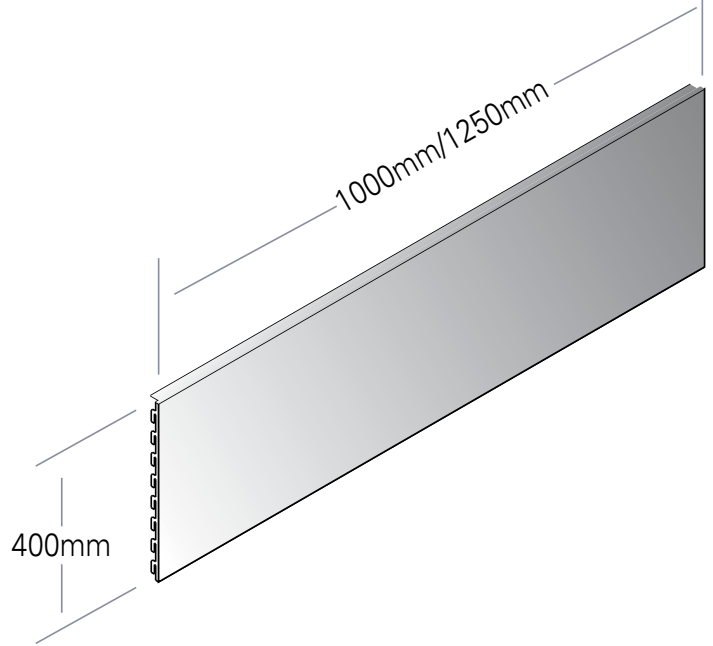

Perforated Back Panel

Product Code

3-4294-24
3-1808-24

Product Description

Perforated Back Panel 1000mm By 400mm, JuraWhite
Perforated Back Panel 1250mm By 400mm, JuraWhite
*Sheet steel perforated back panel with round holes



Jura White

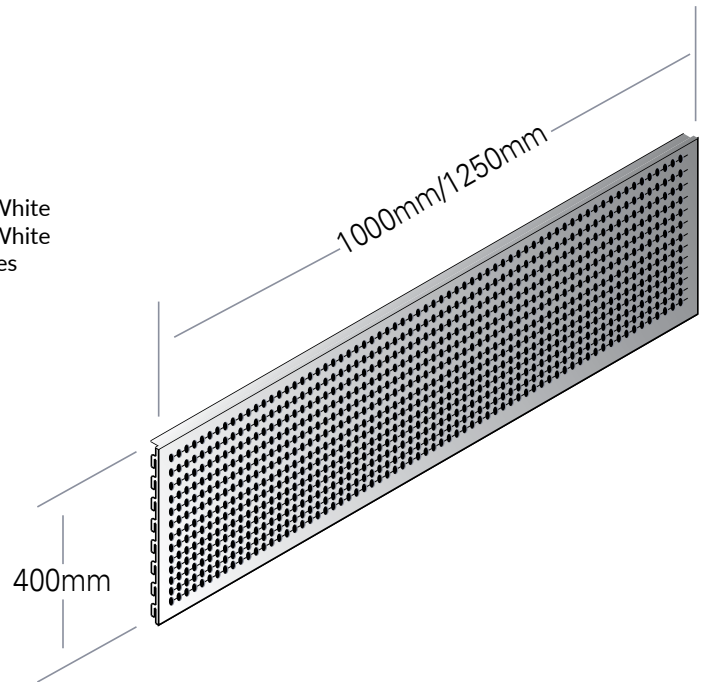

Slatwall Panel

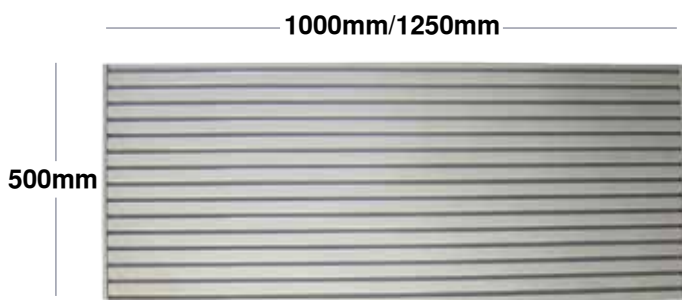

Product Code

HD1
HD2

Product Description

Slatwall Panel 1000mm by 500mm, Jura White/Pure White
Slatwall Panel 1250mm by 500mm, Jura White/Pure White

*Sheet steel slated back panel



Arctic White

Shelves and Shelf Brackets

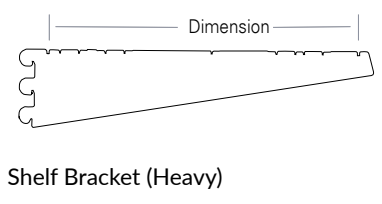
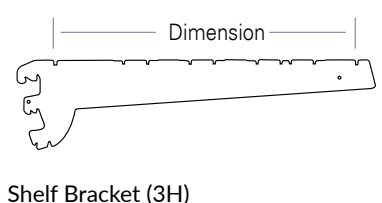
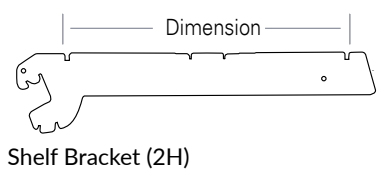
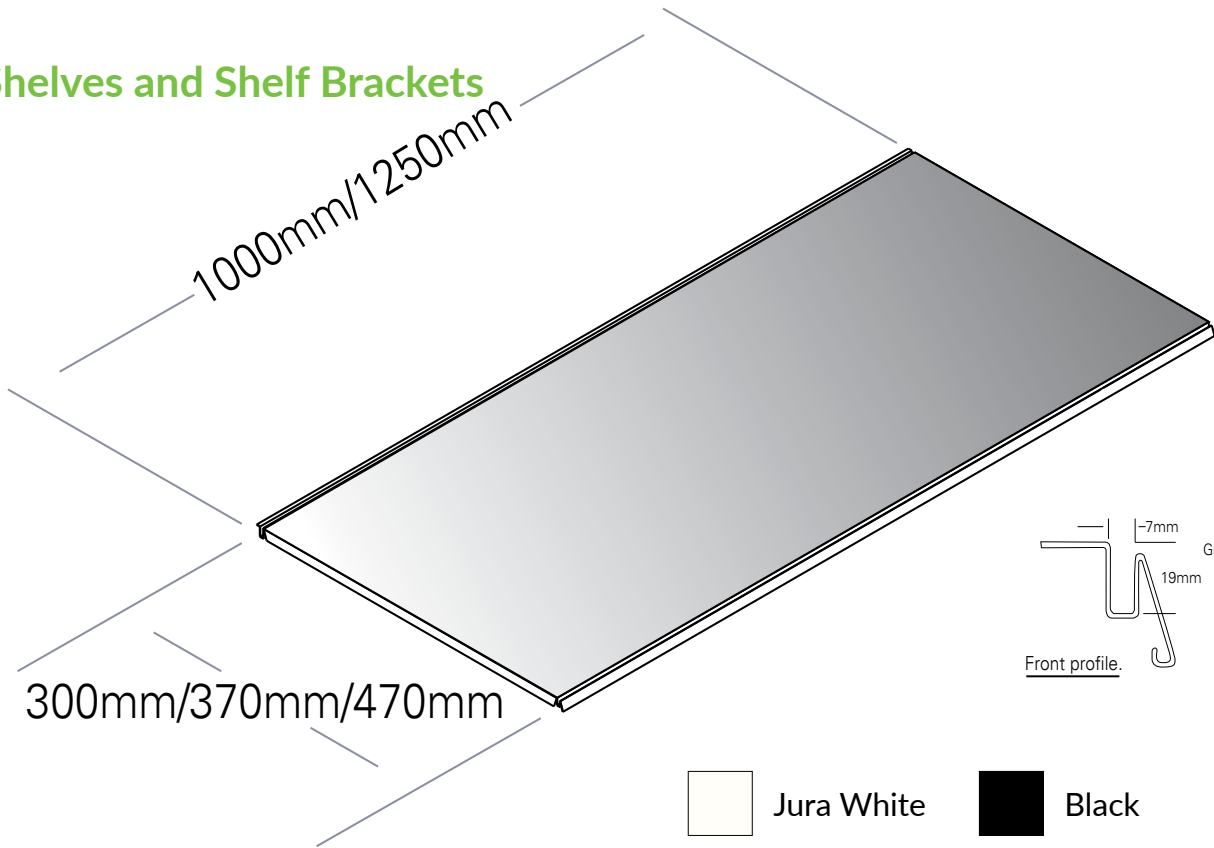

Product Code	Product Description
4-5044-24	Shelves - 1000mm by 300mm
4-1666-24	Shelves - 1000mm by 370mm
4-1667-24	Shelves - 1000mm by 470mm
4-5046-24	Shelves - 1250mm by 300mm
4-1649-24	Shelves - 1250mm by 370mm
4-1660-24	Shelves - 1250mm by 470mm
2-1214-24	Shelf Bracket (2H) 300mm
2-1603-24	Shelf Bracket (2H) 370mm
2-1604-24	Shelf Bracket (2H) 470mm
2-1605-24	Shelf Bracket (3H) 470mm
2-8022-24	Shelf Bracket (Heavy) 470mm

Brackets are supplied in pairs

PRINTED SHELF MATTS

Product Code
IMS402

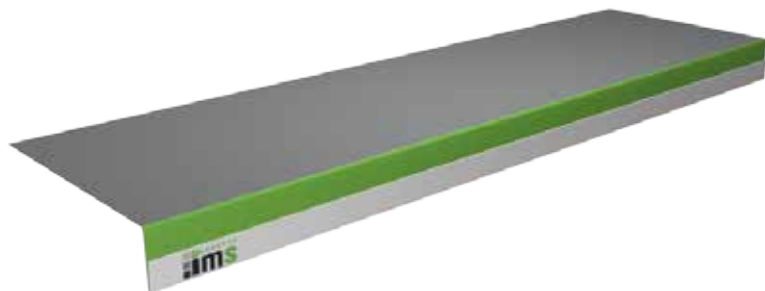

Tegometal Shelf Edge Ticket Strip



800050 / 800051



50-3120-39



300893 / 50-3120-39

Product Code

800050

800051

300893

Red

50-3120-25

Product Description

Tegometal Shelving, 1000mm, Red

Tegometal Shelving, 1250mm, Red

* Shelf edge scanning profile.

Ref 463, to clamp for 39mm labels,

back of profile in red and transparent face.

Self Adhesive 39mm h by 1000mm l, /1250mm l,

*Shelf edge scanning profile.

Ref 320, fitted with 39mm self adhesive

tape back profile in red and transparent face

Label/Ticket Holders 25mm h by 75mm l, White

*Magnetic Tape on rear

Euro Hooks



PB 11016 / PB 14019

Product Code

PB 00000

PB 11016

PB 14019

Product Description

Euro Hooks 3"

Euro Hooks 6"

Euro Hooks 9"

*Heavy-duty hooks to suit 25mm board,

manufactured from 4.5mm diameter

zinc finish steel

Twin Open Tool Holder



1792/200

Product Code

1792/200

Product Description

Twin Open Tool Holder, 200mm by 4.8mm

Single Prong Hooks



SW90

Product Code

SW30

SW60

SW90

Product Description

Single Prong Hook 3"

Single Prong Hook 6"

Single Prong Hook 9"

Metal Clip Strip



Product Code

MSC

Product Description

11 Clips with Header

Clothing Stand

Product Code
FB6

Product Description
Clothing Stand

* Ideal for displaying shirts, jackets
and trousers



Garment Rail



Product Code
5-2896-38

Product Description
Garment Rail, 1000mm

* per garment rail

Z-Shaped Garment Rail



Product Code
6033.2/1000
6033.3/1250

Product Description
Z-Shaped Garment Rail, 1000mm by 1.2mm
Z-Shaped Garment Rail, 1250mm by 1.2mm

Garment Bars



6278.6/500

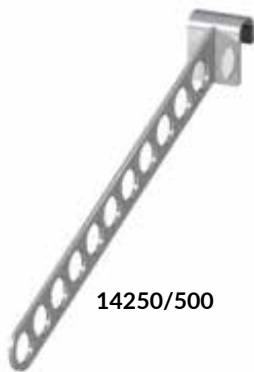

14250/500



F44140



42210



87285

Product Code
6278.6/500
14250/500
F44140
42210
14250/500

Product Description
Raquet or Bag Holder, 500mm by 8mm
Sloping Arm Rail, 500mm
7 Pin Rounded Waterfall Arm, 360mm
12 Notch Waterfall Arm, 450mm
Stepped Arm, 440mm

Shoe / Boot Shelf

Product Code
294

Product Description
Shoe Shelf
312mm L, 144 mmW 160mm D



Wire Boot Display

Product Code
FB7

Product Description
Wire display system
Displays 2 boots



Angled Shoe Shelve

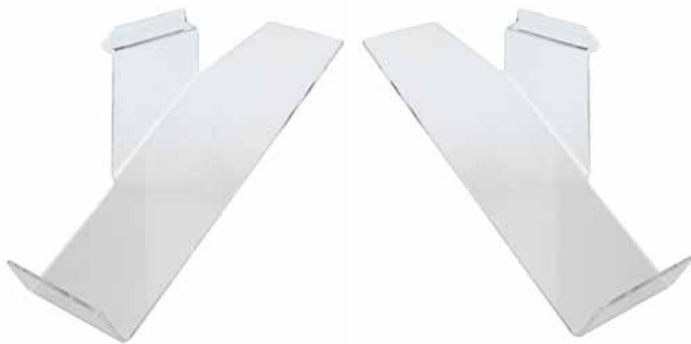

Product Code
87235

Product Description
Sloping Shoe Shelf - Left Facing

Product Code
87236

Product Description
Sloping Shoe Shelf - Right Facing

Clothing Clip

Product Code
FB1506

Product Description
Clothing Clip
Ideal for gloves, boots, overalls etc.



Hat & Helmet Holder

Product Code
281

Product Description
Hat & Helmet Holder for slatwall wall
Jura paint finish, Ø 8.0 mm



Male Mannequin Display Head

Product Code
86086

Product Description
Black Male Mannequin Display Head

Product Code
85995

Product Description
White Male Mannequin Display Head



Stacking Wire Baskets

Product Code
HB4

Product Description
Stacking Wire Baskets

*Bright zinc plated stacking baskets ideal for clothing, hoses, promotions, tools and many other uses



Helmets Display

Product Code
CARP1

Product Description
Welding Helmets

*Ideal for display of welding helmets



Rear Support Bar & Bar Hooks

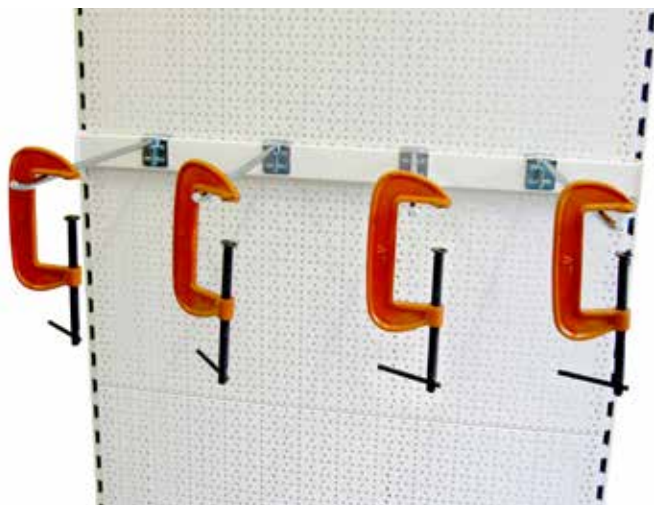

Product Code
5-4764-24
5-4765-24

Product Description
Rear Support Bar, 1000mm
Rear Support Bar, 1250mm

5-1439-37 WD

Notched Bar Hook, 400mm

* To fit above RSB 400mm length



Rear Support Bar



Notched Bar Hook

WIRE BASKETS

C2DS BASKET

10050 mm wide x 680mm deep x 480mm high
Order No. C2DS

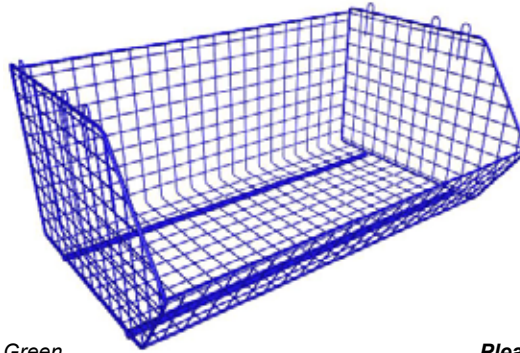

Colours Available: Jurawhite, Red, Blue, Green

Please specify colour required

C2DS BASKET DIVIDER

Order No. for C2DS-D

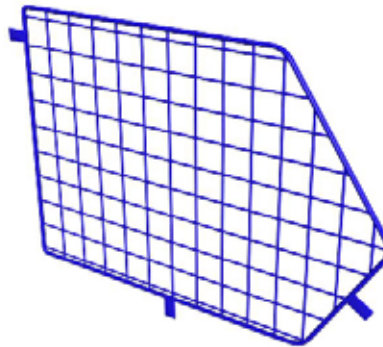

Colours Available: Jurawhite, Red, Blue, Green

Please specify colour required

C17 BASKET

Order No. C17

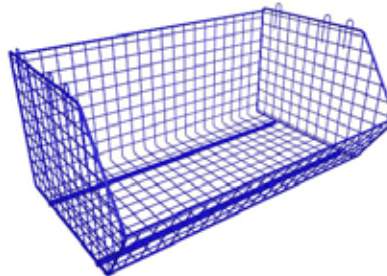

Colours Available: Jurawhite, Red, Blue, Green

Please specify colour required

C17 BASKET DIVIDER

Available in Blue and Green.
Order No. C17-D

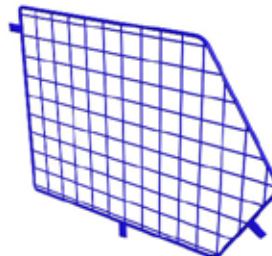

Colours Available: Jurawhite, Red, Blue, Green

Please specify colour required

Mesh Shelving

Product Code	Product Description
83723	Small Mesh Shelf, Silver
F44408	Small Mesh Shelf, Chrome
83724	Large Mesh Shelf, Silver
F44409	Small Mesh Shelf, Chrome



Straight Acrylic Shelves

Product Code	Product Description
86909	25 x 10cm
86910	30 x 15cm
82876	30 x 20cm
86911	30 x 30cm
86912	40 x 20cm
86914	60 x 20cm
86915	60 x 30cm



Straight Acrylic Shelves with 30mm front lip

Product Code	Product Description
86900	25 x 7.5cm
86901	25 x 10cm
82751	30 x 15cm
82753	30 x 30cm
86904	40 x 20cm
86905	40 x 30cm
82752	60 x 20cm
82754	60 x 30cm



Multi-compartment acrylic bins

Product Code	Product Description
87289	3-Comp, 58 x 25 x 15cm
87933	7-Comp, 60 x 15 x 7.5cm



Eye Protection Display

Product Code
CADGS

Product Description
Eye Protection Display

Eye protection shelf to display both box stock and demonstration model

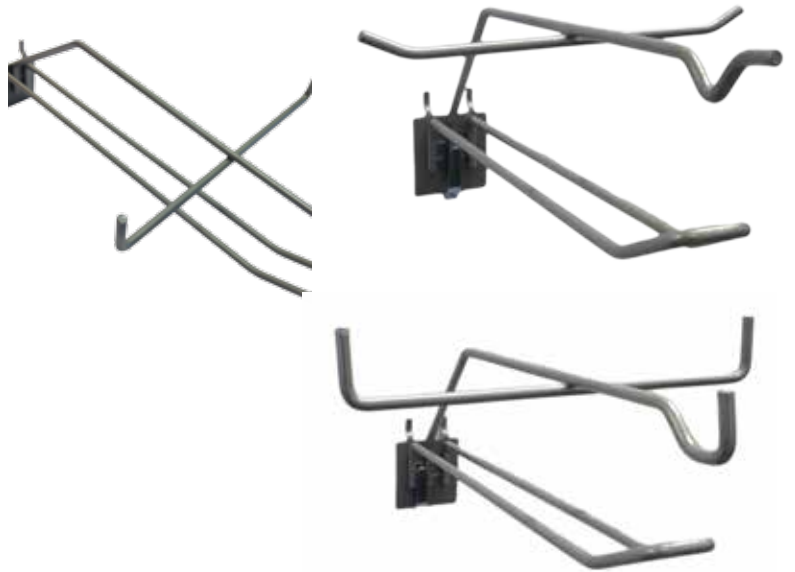

Regulator Display Shelf

Product Code
REGSHELF

Product Description
Regulator Display Shelf

*New style regulator shelf to allow three regulators to be displayed on one shelf

Nozzle Display

Product Code
HITNZ

Product Description
Nozzle Display

*Stands on a Min 370mm shelf

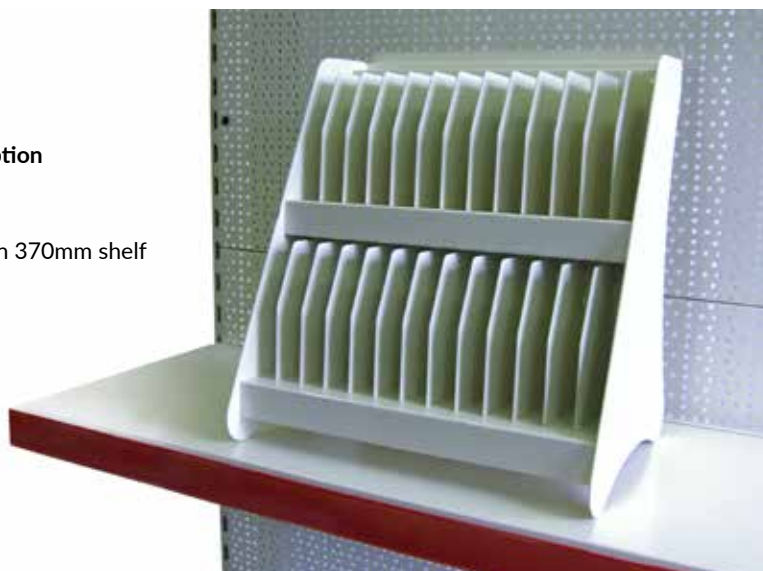

Hose Display Shelf

Product Code
CADHR

Product Description
Hose display shelf

*Designed to allow hoses to be merchandised in a quick and simple manner



Welding Rod Shelf

Product Code
CAR2

Product Description
Welding Rod Display Shelf



Drill Holder

Product Code
CDH

Product Description
Drill holder for slatwall wall



Jura White

Grinder Holder

Product Code
CGH

Product Description
Grinder holder for slatwall wall

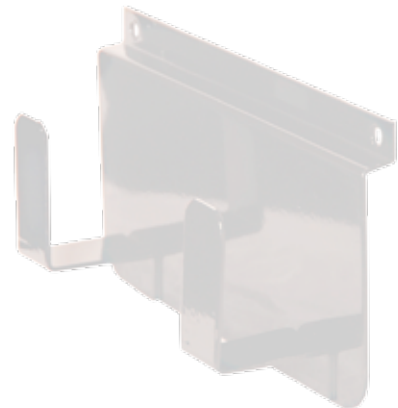

Cable Box

Product Code
CB1

Product Description
Cable box holder for slatwall wall



Jura White



CABLE REEL HOLDER

1000mm & 1250mm Cable Reel Holder to fit

Order No. for 1000mm: CRH 1000

Order No. for 1250mm: CRH 1250

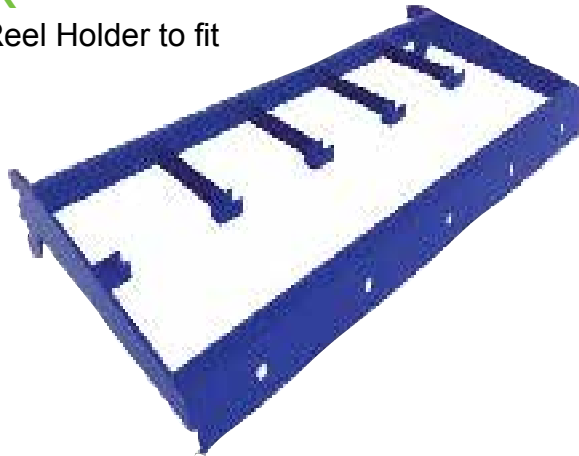

Colours Available: Jurawhite, Red, Blue, Green

Please specify colour required

CABLE REEL HOLDER METER RULE

1000mm Cable Reel Holder Rule
to fit the above Cable Reel Holder

Order No: MTR 1



Centre Shop Display Unit

Product Code Product Description
F45285 Centre Shop Display Unit
 Centre Shop Display Unit

*Centre shop display unit ideal for displaying helmets, masks, power tools & Boots



Freestanding Dump Bin

Product Code Product Description
DSSDBEB Dump Bin

*Ideal for displaying gloves, clothing, safety wear & any other promotional lines.



A4 Bus Stop Sign

Product Code Product Description
POS7 A4 Bus Stop Sign, 800mm high



Pallet Cover

Product Code
4021120

Product Description
Pallet Cover 1200mm by 800mm

Aluminium checker plate pallet cover suitable to fit over a standard Euro pallet, still allowing access for pallet truck.

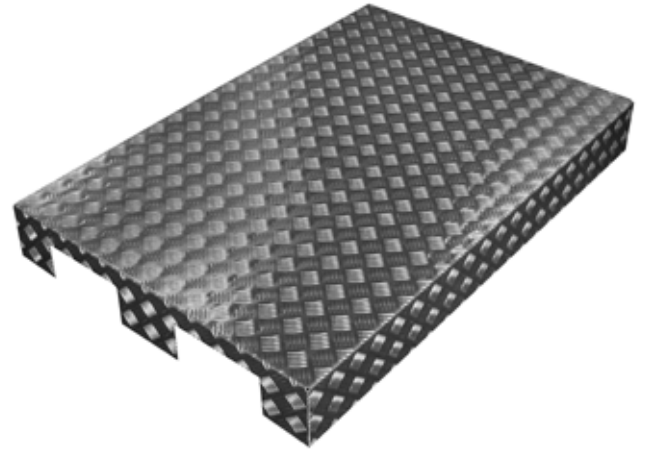

PLINTH & PALLET WRAPS

Height: 350mm Width: 1000mm

Product Code
4021121



Pallet Racking

Product Code **Product Description**
KRB2700/900/3500
2700 wide x 900 deep x 3500 high



Longspan Racking

Product Code **Product Description**
KRB1800/500/2200
1800 wide x 500 deep x 2200 high



A4 Leaflet Holder

Product Code
CDE1

Product Description
A4 Leaflet Holder
Wall fixed or free standing



Card & poster holders

Product Code
F40593
87231
87230
87249
AS51/3A4P

Product Description
A6 Portrait
A5 Portrait
A4 Portrait
A3 Portrait
A4 Acrylic Poster Sleeve



F40593



AS51/3A4P

A4 Counter Top Display

Product Code
SD11

Product Description
A4 Counter Top Display



A1 Clip Frame

Product Code
PFG1

Product Description
A1 Clip Frame



A1 'A' Frame Sign

Product Code
ABG1A1

Product Description
A1 'A' Frame Sign



A4 Upright Card Display

Product Code
83104

Product Description
A4 Upright Card Display



Suspension Kit

Product Code
DHW1-4

Product Description
Suspension Kit
Available in a variety of sizes



Counter Unit

Product Code
W1500

Product Description
Counter Units



Till Drawer

Product Code
EC-410

Product Description
Till Drawer



Work Bench

Product Code
3003157L

Product Description
Steel Workbench with Laminate
Worktop 450kg



Display Tables

Product Code
83810

Product Description
Chrome display tables - set of 2



BRANCH SIGNAGE

GONDOLA GOAL POST

Order No. GP800



GONDOLA ADJUSTABLE BRACKETS

Packed in pairs
Order No. GP002



GONDOLA SIGNAGE

150mm x 800mm, 3mm foamex
Order No. GS158



Signs Available:

ADHESIVES
BUILDERSMETALWORK
FIXINGS
PLUMBING
TIMBERCARE/JOINERY
ELECTRICAL

TOOLS
PAINT
DECORATING
ROOFING/RAINWATER
IRONMONGERY
VENTILATION

DRAFT PROOFING
NAILS
SCREWS
KITCHEN ACCESSORIES
BATHROOM ACCESSORIES
CLOTHING

WORKWEAR
BOOTS
PPE
SAFETY

Custom Text Available



Colours Available: Jurawhite, Red, Blue, Yellow, Green

Please specify colour required

PELMET SIGNAGE

600mm x 2400mm, 3/5mm foamex
Order No. PS624



Signs Available:

DEC CENTRE
GARDENING
IRONMONGERY
ELECTRICS
TOOLS

KITCHEN/BATHROOM
ROOFING
HIRE
POWER TOOLS

TIMBER
INSULATION
SHEET MATERIALS
SECURITY



Colours Available: Jurawhite, Red, Blue, Yellow, Green

Please specify colour required

YARD SIGNAGE

350mm x 900mm, 3/5mm foamex
Order No. YS359



Signs Available:

AGGREGATE
LINTELS
DECORATIVE
BRICKS & BLOCKS

TIMBER
FENCING
DECORATIVE
DRAINAGE

ROOFING
CONCRETE PRODUCTS
DECKING



Colours Available: Jurawhite, Red, Blue, Yellow, Green

Please specify colour required

GENERAL BRANCH SIGNAGE

CAR PARK 1

Height: 800mm
Width: 1200mm
Order No: SS-101

Signs can be produced to suit
Merchant colour scheme

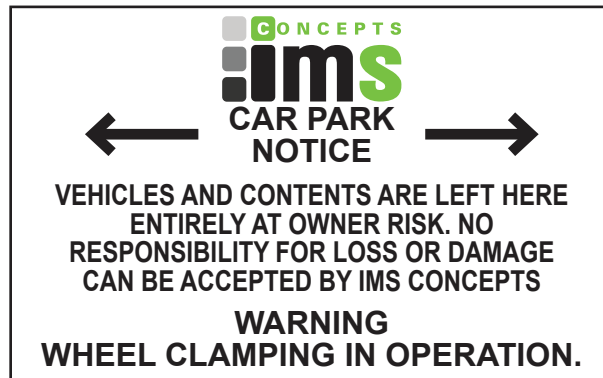

CAR PARK 2

Height: 450mm
Width: 600mm
Order No: SS-102

Signs can be produced to suit
Merchant colour scheme



CUSTOMER ENTRANCE

Height: 1200mm
Width: 3000mm
Order No: SS-103

Signs can be produced to suit
Merchant colour scheme



CUSTOMER NOTICE 1

Height: 915mm
Width: 1220mm
Order No: SS-104

Signs can be produced to suit
Merchant colour scheme



GENERAL BRANCH SIGNAGE

CUSTOMER NOTICE 2

Height: 1000mm
Width: 1220mm
Order No: SS-105

Signs can be produced to suit
Merchant colour scheme



CUSTOMER NOTICE 3

Height: 600mm
Width: 900mm
Order No: SS-106

Signs can be produced to suit
Merchant colour scheme



CUSTOMER NOTICE 4

Height: 300mm
Width: 600mm
Order No: SS-106

Signs can be produced to suit
Merchant colour scheme



FLAG

Height: 1200mm
Width: 2250mm
Order No: SS-107

Signs can be produced to suit
Merchant colour scheme



GENERAL BRANCH SIGNAGE PACKAGE

All signs on Pages 20 & 21 are included in the General Sign Package.
One of each sign included unless otherwise stated.



400 x 150



400 x 150



400 x 150



400 x 150



400 x 150



400 x 150



400 x 150



400 x 150



200 x 300



750 x 150



300 x 200 - x 2



750 x 150



200 x 300



200 x 300



400 x 600



400 x 600



590 x 420



590 x 420

GENERAL BRANCH SIGNAGE

To order Signage Package use SSB610 Code



Self adhesive labels supplied on the roll. 100 labels per roll. Each label 100 x 100



150 x 50 - x 6



300 x 100 - x 4



300 x 100 - x 4



200 x 300 - x 2



200 x 300 - x 2



200 x 300 - x 2



400 x 300 - x 2

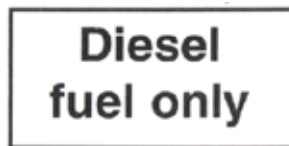

100 x 50



300 x 300 - x 4



125 x 150

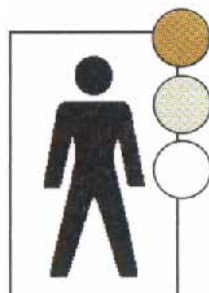

125 x 200

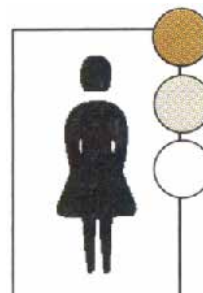

125 x 200



300 x 400 - x 2

Feather Flags & Base

Product Code Product Description

SS-232 **Flag**

Small Feather Flag 2600mm Tall
 Medium Feather Flag 3200mm Tall
 Large Feather Flag 4000mm Tall
 Extra Large Feather Flag 4900mm Tall



Pull Up Banners

Product Code	Product Description	Size
SS-237	POP UP PVC BANNER Supplied with wire support frame	Height: 1800mm Width: 800mm

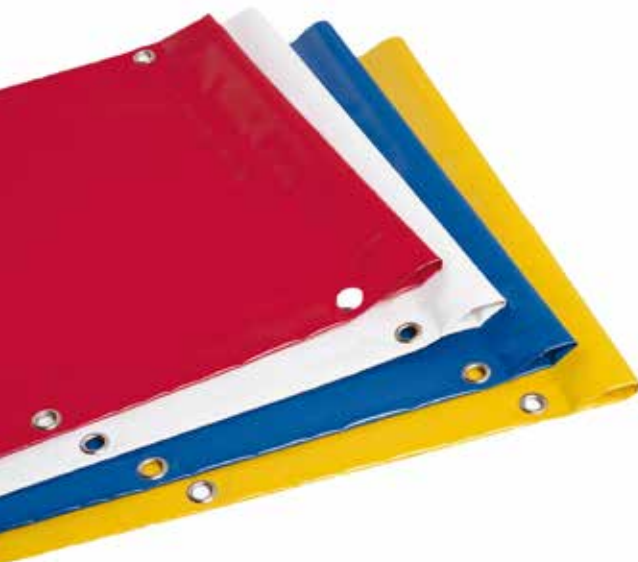

PVC Outdoor Banners

Product Code	Product Description	Size
SS-233	External PVC Banner Signs can be produced to suit Merchant Colour scheme	Height: 1000mm Width: 3000mm

DELIVERY CHARGES & MAP

Zone A	£6.00	per consignment to	20 kilos	each additional kilo	26p
Zone B	£6.00		20 kilos		26p
Zone C	£16.00		20 kilos		50p
Zone D	£18.00		20 kilos		50p
Zone E	£16.00		20 kilos		50p

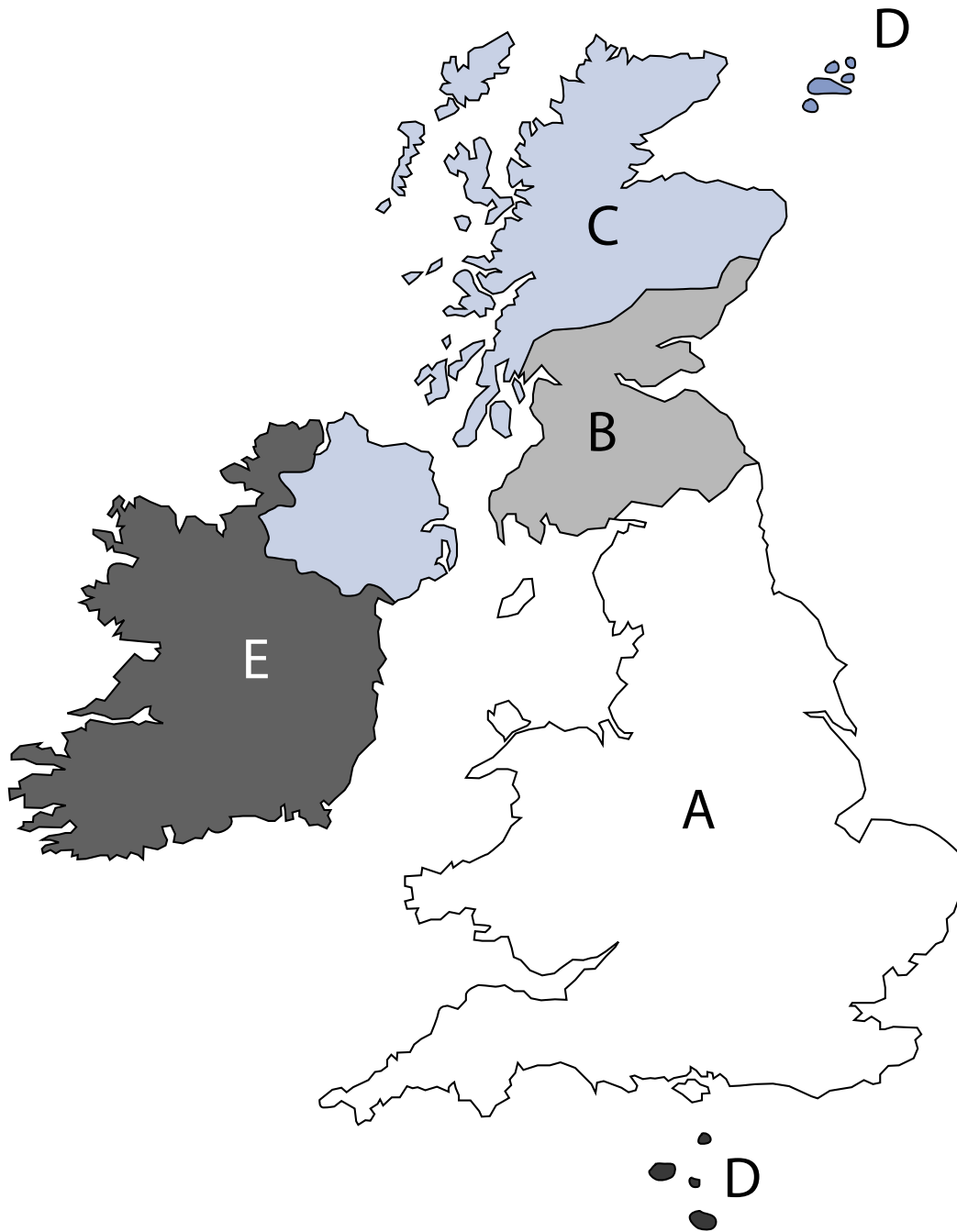

IMS Concept

Tel 01422 377385 Email: david.imsconcepts@gmail.com

Order Number

Store Name / Store Plant Number

Address

.....

.....

Contact Name

Contact Number

Contact e-mail

CODE	DESCRIPTION	COLOUR	QTY.